

# NNU 4926 B/SPW33

## Super-precision double row cylindrical roller bearing with lubrication feature

Super-precision double row cylindrical roller bearings in the NNU 49 series are designed to accommodate heavy radial loads and high speeds, while providing a high degree of stiffness. Having three flanges on the outer ring and no flanges on the inner ring, the bearings can accommodate axial displacement in both directions. The separable design simplifies mounting and dismounting, particularly when load conditions require both rings to have an interference fit.

- High radial load carrying capacity
- Very high rigidity and high running accuracy
- Minimize noise, vibration and heat generation
- Accommodate axial displacement in both directions
- Lubrication feature
- Thin section enabling compact application design



### Overview

### Dimensions

|                  |        |
|------------------|--------|
| Bore diameter    | 130 mm |
| Outside diameter | 180 mm |
| Width            | 50 mm  |

### Performance

|  |             |
|--|-------------|
| Basic dynamic load rating                | 187 kN      |
| Basic static load rating                 | 390 kN      |
| Attainable speed for grease lubrication  | 4 300 r/min |
| Attainable speed for oil-air lubrication | 4 800 r/min |

### Properties

|                               |                  |
|-------------------------------|------------------|
| Bearing part                  | Complete bearing |
| Number of rows                | 2                |
| Bore type                     | Cylindrical      |
| Cage                          | Machined metal   |
| Design                        | NNU              |
| Number of flanges, outer ring | 3                |
| Number of flanges, inner ring | 0                |
| Loose flange                  | None             |
| Radial internal clearance     | C1               |
| Tolerance class               | Class SP (SP)    |
| Material, bearing             | Bearing steel    |

|                       |                                      |
|-----------------------|--------------------------------------|
| Coating               | Without                              |
| Sealing               | Without                              |
| Lubricant             | None                                 |
| Relubrication feature | Annular groove and lubrication holes |

# Technical Specification

Bore type

Cylindrical

## Dimensions

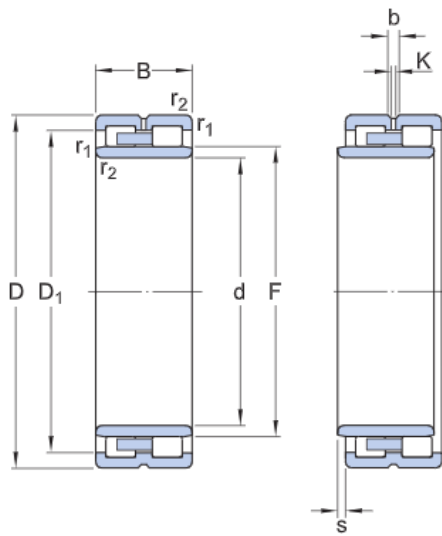

|                  |             |   |
|------------------|-------------|---|
| d                | 130 mm      | Bore diameter   |
| D                | 180 mm      | Outside diameter  |
| B                | 50 mm       | Width   |
| D <sub>1</sub>   | 162 mm      | Shoulder diameter outer ring (NNU design)   |
| F                | 146 mm      | Raceway diameter inner ring (NNU design)  |
| b                | 5.5 mm      | Width annular lubrication groove at outer ring  |
| K                | 3 mm        | Diameter lubrication hole (outer ring)  |
| r <sub>1,2</sub> | min. 1.5 mm | Chamfer dimension outer ring  |
| r <sub>3,4</sub> | min. 1.5 mm | Chamfer dimension inner ring (bearing with tapered bore)  |
| s                | max. 2.2 mm | Permissible axial displacement from the normal position of one bearing ring relative to the other (all) |

## Abutment dimensions

|                |             |  |
|----------------|-------------|--|
| d <sub>a</sub> | min. 137 mm | Abutment diameter shaft                                    |
| d <sub>a</sub> | max. 144 mm | Abutment diameter shaft (NNU design)                       |
| d <sub>t</sub> | min. 149 mm | Abutment diameter shaft (NNU design; not for tapered bore) |

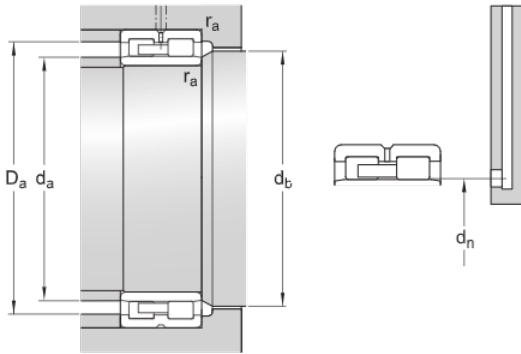

|                   |   |
|-------------------|---|
| $D_i$ max. 172 mm | Abutment diameter housing                             |
| $r_a$ max. 1.5 mm | Fillet radius   |
| $d_r$ 147 mm      | Oil nozzle position (not for variants with TNHA cage) |

## Calculation data

|   |           |                  |
|---|-----------|------------------|
| Basic dynamic load rating                 | C         | 187 kN           |
| Basic static load rating                  | $C_0$     | 390 kN           |
| Fatigue load limit                        | $P_u$     | 41.5 kN          |
| Attainable speed for grease lubrication   |           | 4 300 r/min      |
| Attainable speed for oil-air lubrication  |           | 4 800 r/min      |
| Reference grease quantity                 | $G_{ref}$ | 31 cm            |
| Static radial stiffness (guideline value) |           | 3 570 N/ $\mu$ m |

## Mass

|              |         |
|--------------|---------|
| Mass bearing | 3.85 kg |
|--------------|---------|

# Terms and conditions

By accessing and using this website / app owned and published by AB SKF (publ.) (556007-3495 - Gothenburg) ("SKF"), you agree to the following terms and conditions:

## Warranty Disclaimer and Limitation of Liability

Although every care has been taken to assure the accuracy of the information on this website / app, SKF provides this information "AS IS" and DISCLAIMS ALL WARRANTIES, EXPRESS OR IMPLIED, INCLUDING, BUT NOT LIMITED TO, IMPLIED WARRANTIES OF MERCHANTABILITY AND FITNESS FOR A PARTICULAR PURPOSE. You acknowledge that your use of this website / app is at your sole risk, that you assume full responsibility for all costs associated with use of this website / app, and that SKF shall not be liable for any direct, incidental, consequential, or indirect damages of any kind arising out of your access to, or use of the information or software made available on this website / app. Any warranties and representations in this website / app for SKF products or services that you purchase or use will be subject to the agreed upon terms and conditions in the contract for such product or service. Further, for non-SKF websites / apps that are referenced in our website / app or where a hyperlink appears, SKF makes no warranties concerning the accuracy or reliability of the information in these websites / apps and assumes no responsibility for material created or published by third parties contained therein. In addition, SKF does not warrant that this website / app or these other linked websites / apps are free from viruses or other harmful elements.

## Third Party Services

When viewing YouTube content via the SKF website(s) (i.e. using YouTube API Services), you agree to be bound by the YouTube Terms of Service.

## Copyright

Copyright in this website / app copyright of the information and software made available on this website / app rest with SKF or its licensors. All rights are reserved. All licensed material will reference the licensor that has granted SKF the right to use the material. The information and software made available on this website / app may not be reproduced, duplicated, copied, transferred, distributed, stored, modified, downloaded or otherwise exploited for any commercial use without the prior written approval of SKF. However, it may be reproduced, stored and downloaded for use by individuals without prior written approval of SKF. Under no circumstances may this information or software be supplied to third parties.

This website / app includes certain images used under license from Shutterstock, Inc.

## Trademarks and Patents

All trademarks, brand names, and corporate logos displayed on the website / app are the property of SKF or its licensors, and may not be used in any way without prior written approval by SKF. All licensed trademarks published on this website / app reference the licensor that has granted SKF the right to use the trademark. Access to this website / app does not grant to the user any license under any patents owned by or licensed to SKF.

## Changes

SKF reserves the right to make changes or additions to this website / app at any time.